



# Instruction Sheet

## Variable Speed - Solar (00-VT)

### "00" and Load Match® Cartridge Circulators

102-358

SUPERSEDES: New

EFFECTIVE: January 1, 2009

Plant ID# 001-3921

The Variable Speed - Setpoint "00" Cartridge Circulator (00-VT) is a microprocessor-based pump designed to regulate the temperature difference between a solar thermal collector and storage tank through variable speed injection mixing.

### Applications

The following are typical applications the 00-VT supports. The 00-VT includes a five DIP package with DIP switches 1 and 2 used to configure the control for a given application. DIP switch 3 is used to select the drainback feature. DIP switch 4 is used to select the intermittent freeze protection feature.

DIP switch 5 is used to select whether one or two storage tanks is used.

#### 00-VT-1: Single Storage Tank

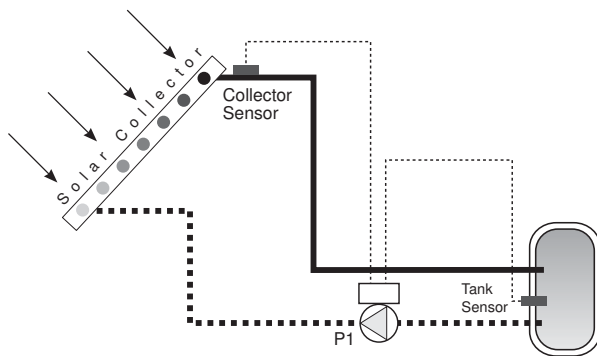

#### Essential Settings

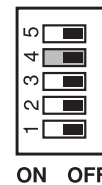

The 00-VT adjusts the variable speed output to the collector pump P1 to maintain a setpoint temperature difference ( $\Delta T$ ) between the collector sensor and the tank sensor.

#### 00-VT-2: Single Storage Tank, Heat Exchanger

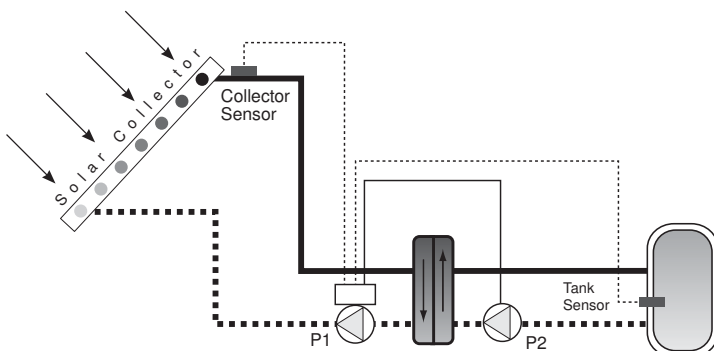

#### Essential Settings

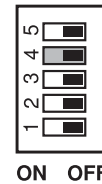

The 00-VT adjusts the variable speed output to the collector pump P1 to maintain a setpoint temperature difference ( $\Delta T$ ) between the collector sensor and the tank sensor. A heat exchanger is included to isolate the collector from the storage tank. The storage tank pump P2 operates in parallel with the collector pump P1.

#### 00-VT-3: Single Storage Tank, Storage Tank Supplement

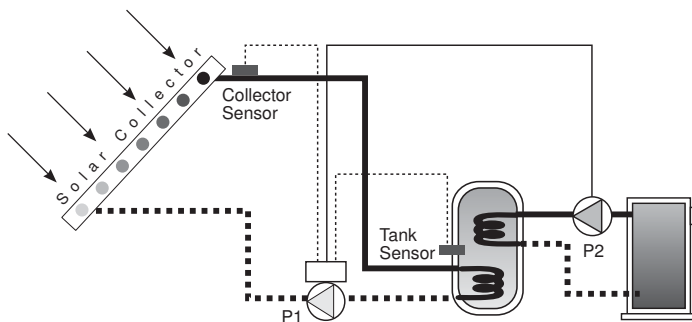

#### Essential Settings

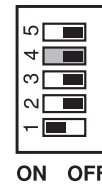

The 00-VT adjusts the variable speed output to the collector pump P1 to maintain a setpoint temperature difference ( $\Delta T$ ) between the collector sensor and the tank sensor. A boiler is included to supplement the storage tank. The boiler and boiler pump P2 operate independently from the collector to maintain the storage tank at a setpoint temperature.

**00-VT-4: Single Storage Tank, Auxiliary Heat Sink**

**Essential Settings**

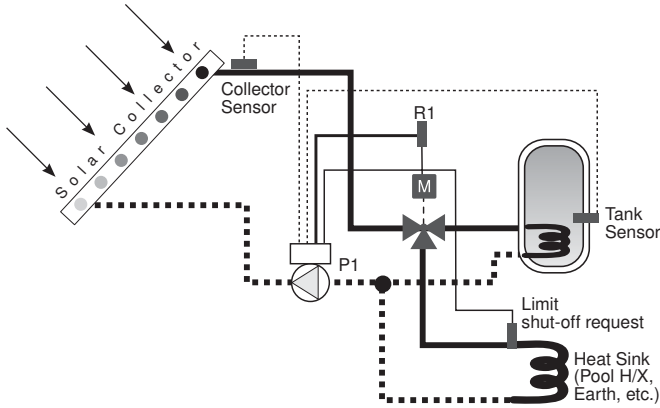

The 00-VT adjusts the variable speed output to the collector pump P1 to maintain a setpoint temperature difference ( $\Delta T$ ) between the collector sensor and the tank sensor. An auxiliary heat sink is included to accept heat in the event both the storage tank and the collector become too hot. During this condition, the diverting valve operates and the collector pump runs at full speed to transfer heat from the collector to the auxiliary heat sink.

**00-VT-5: Single Storage Tank, Drainback, Booster Pump**

**Essential Settings**

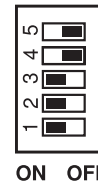
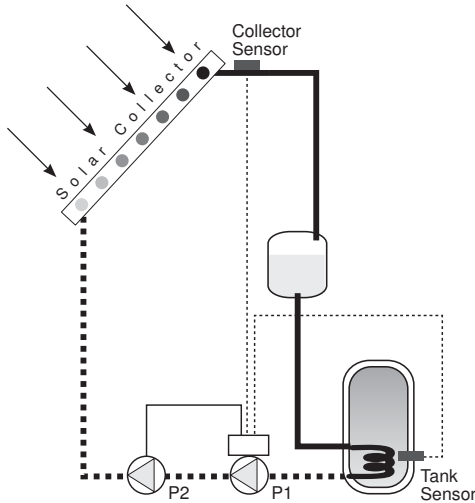

The 00-VT adjusts the variable speed output to the collector pump P1 to maintain a setpoint temperature difference ( $\Delta T$ ) between the collector sensor and the tank sensor in a drainback system. A booster pump is included in order to provide the necessary head requirements on startup to fill the system. When operation is required, the control turns on the booster pump and operates the collector pump at full speed for 3 minutes. After the 3 minute period elapses, the booster pump turns off and the collector pump operates to maintain the setpoint temperature difference. When operation is not required, the control turns off the collector pump draining the fluid back into the drainback tank.

**00-VT-6: Two Storage Tanks**

**Essential Settings**

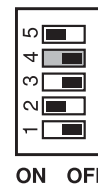
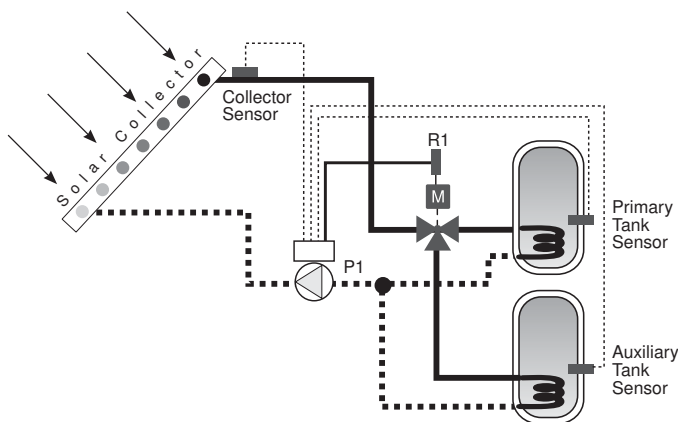

The 00-VT provides operation for two storage tanks. When operation is required for the primary storage tank, the control adjusts the variable speed output to the collector pump P1 to maintain a setpoint temperature difference ( $\Delta T$ ) between the collector sensor and the primary tank sensor. When the primary storage tank is satisfied, the control switches to provide operation for the auxiliary storage tank. For the auxiliary storage tank, the control operates the diverting valve and adjusts the variable speed output to the collector pump P1 to maintain a setpoint temperature difference between the collector sensor and the auxiliary tank sensor. Note: the holiday feature is not available.

**SEQUENCE OF OPERATION**

Whenever the 00-VT is powered up, the green PWR LED turns on and operates to maintain a setpoint temperature difference ( $\Delta T$ ) between a heat source (solar collector) and a heat sink (storage tank). The percent output (% OUT) LED flashes at different rates based on the speed of the collector pump. As the % OUT LED flashes faster it indicates a faster speed of the pump. A fully on LED indicates the pump is at 100% capacity.

## Mixing Operation

The 00-VT operates the collector pump to transfer heat between the collector and a storage tank based on a setpoint temperature difference (delta T) and setpoint temperature difference differential. The setpoint temperature difference is fixed at 10°F and the setpoint temperature difference differential is fixed at 5°F.

For delta T operation, the collector pump operates between the minimum variable speed output and full speed. Once the actual temperature difference rises to at least 10°F, the collector pump turns on at full speed for 10 seconds. After 10 seconds, the collector pump operates to maintain the 10°F setpoint target temperature difference. As the actual temperature difference increases, the variable speed output is increased. As the actual temperature difference decreases, the variable speed output is decreased. Once the actual temperature difference falls to the 5°F setpoint target temperature difference differential, the collector pump is turned off.

The 00-VT allows for operation with a single storage or two storage tanks. With a single storage tank, the control uses the collector pump to provide delta T operation between the collector and the primary storage tank. The auxiliary relay can then be configured for heat exchanger, collector sink, tank supplement or booster pump operation. With two storage tanks, the control uses the collector pump and auxiliary relay together to provide delta T operation between the collector and the second storage tank. With two storage tanks, the application configuration must be assigned to collector sink.

When configured for two storage tanks, operation for the primary storage tank is independent from the second storage tank. Delta T operation occurs first for the storage which requires it. However, the primary storage tank has priority over the second storage tank. In this case, if the control is providing delta T operation for the second storage tank and delta T operation is required for the primary storage tank, the control will turn off the auxiliary relay and use only the collector pump to provide operation for the primary storage tank. This could be typical of an application where the primary storage tank is the Domestic Hot Water (DHW) tank.

## Minimum Variable Speed Output

The 00-VT includes a minimum variable speed output for the collector pump during delta T operation in which the variable speed output is adjusted between 30% output and full output.

## Tank Maximum Operation

The 00-VT includes a tank maximum feature that conditionally ceases operation if the storage tank reaches the maximum tank setpoint temperature. If during delta T operation the tank temperature rises to the maximum tank setpoint temperature, the control turns off the collector pump and, if applicable, the auxiliary relay. The collector pump and, if applicable, auxiliary relay then remain off until the tank temperature falls to the maximum tank setpoint temperature less the maximum tank setpoint temperature of 5°F. The maximum tank setpoint temperature is set using the dial. Subsequent operation is dependent on the application configuration and the other control features.

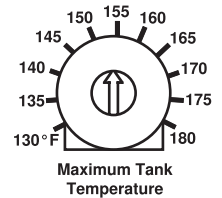

## Tank Limit Operation

The 00-VT includes a tank limit feature that ceases operation if the storage tank reaches its upper limit during collector maximum operation. This scenario could occur if operation first ceases during delta T operation when the storage tank reaches the maximum tank setpoint temperature resulting in potential collector stagnation conditions. Collector Maximum operation would then occur in an attempt to cool the collector while further heating the storage tank to its upper limit. If during collector maximum operation the tank temperature rises to the tank limit temperature of 200°F, the control turns off the collector pump and, if applicable, the auxiliary relay. The collector pump and, if applicable, auxiliary relay then remain off until the tank temperature falls to 190°F.

The tank limit operation is not available when the control is configured for drainback.

## Collector Maximum Operation

The 00-VT includes a collector maximum feature that operates the collector pump, and if applicable, the auxiliary relay to transfer heat from the collector to the storage tank in the event the collector becomes too hot due to stagnation conditions. This scenario could occur if the tank maximum operation ceases delta operation causing the collector to stagnate and become too hot. If the tank temperature is at least the tank maximum temperature and the collector temperature rises to collector maximum temperature of 230°F, the control turns on the collector pump and, if applicable, the auxiliary relay to further heat the storage tank. The collector pump and, if applicable, auxiliary relay then remain on until either the collector temperature falls to 220°F or the tank temperature rises to the tank limit temperature of 200°F.

The collector maximum operation is not available when then control is configured for drainback.

## Collector Limit Operation

The 00-VT includes a collector limit feature that turns off all outputs if the collector temperature reaches its upper limit in an attempt to protect the solar system components. In the event the collector pump and, if applicable, auxiliary relay are operating and the collector temperature rises to the collector limit temperature of 250°F, the control turns off all outputs. All outputs then remain off until the collector temperature falls to 240°F.

The collector limit operation is not available when then control is configured for drainback.

## Drainback (DIP Switch 3)

The 00-VT supports a drainback feature. In a drainback system, the control turns off the collector pump when operation is no longer required. Once the collector pump turns off, the fluid in the collector and distribution piping drains back into reservoir. Once operation is required, the fluid in the tank must be circulated through the collector and throughout the distribution. In order to ensure that the fluid is properly circulated throughout the solar system with all the air purged out, the collector pump operates at full speed for a 3 minute period when operation is required. After the 3 minute period, the 00-VT operates the collector pump based on the variable speed injection requirements.



## Heat Exchanger

When the application is configured for heat exchanger, the auxiliary relay is used to operate a pump that provides flow from the heat exchanger to the storage tank. A heat exchanger may be included to isolate the fluid in the storage tank from the fluid in the collector. In this application configuration, the auxiliary relay operates in parallel with the collector pump.



When configured for heat exchanger and delta T operation is required, the control turns on the auxiliary relay and operates the collector pump accordingly.

## Collector Sink (single tank operation)

When the application is configured for collector sink with a single storage tank, the auxiliary relay is used to operate a device such as a mixing valve actuator that can divert flow from the collector to an auxiliary heat sink in the event the storage tank reaches the tank limit temperature and the collector reaches the collector maximum temperature. The heat sink acts as a mechanism to absorb heat, thereby preventing the collector from being compromised.



If the storage tank reaches the tank limit temperature during collector maximum operation the control then adjusts the collector pump to full speed and turns on the auxiliary relay operating the diverting valve to direct flow from the collector to an auxiliary heat sink. The auxiliary relay then remains on along with the collector pump at full speed until either the collector temperature falls to 220°F, the storage tank temperature falls to 190°F, or a limit input is received. However, a limit input will only cease operation between the collector and the auxiliary heat sink. Operation can still occur between the collector and storage tank regardless of the limit input.

## Collector Sink (double tank operation)

When the application is configured for collector sink with two storage tanks, the control uses the collector maximum feature to provide collector sink operation with each tank being independent from one another. The control uses the collector pump to provide collector maximum operation to the primary storage tank while the collector pump and auxiliary relay are used to provide collector maximum operation to the second storage tank. The 00-VT provides priority for the primary storage tank over the second storage tank.



If the control is operating between the collector and a storage tank and the storage tank rises to the maximum tank setpoint temperature, and delta T operation is required for the other storage tank, the control switches to provide operation to the other storage tank. If then that other storage tank reaches the tank maximum setpoint temperature, the control operates to provide collector maximum operation. Once that storage tank reaches the tank limit temperature, the control switches to provide collector maximum operation for the storage tank which first required operation. If the control is operating to provide collector maximum operation for a storage tank, the collector pump and, if applicable, auxiliary relay remain on until either the collector temperature falls to 220°F, the operating storage tank temperature falls to 190°F or a limit input is received. If the control is operating to provide collector maximum operation for the non-priority storage tank, operation terminates for the non-priority storage tank and switches to the priority storage tank if the primary storage tank requires operation.

If the control is operating between the collector and a storage tank and the storage tank rises to the maximum tank setpoint temperature, and delta T operation is not required for the other storage tank, the control operates to provide collector maximum operation for the storage tank first requiring operation.

## Tank Supplement

When the application is configured for tank supplement, the auxiliary relay is used to operate a device that supplements the storage tank. This device includes a heat source such as an instantaneous water heater, boiler, heat pump or other alternate heat source. The control operates the supplemental heat source to maintain the storage tank at 130°F. The operation of the collector is independent of the operation of supplemental heat source.



When configured for tank supplement operation and the storage tank temperature drops to 130°F, the control turns on the auxiliary relay. The auxiliary relay then remains on until either the storage tank temperature rises to 135°F or until a limit input is received.

## Booster Pump

When the application is configured for booster pump, the auxiliary relay is used to operate a high head pump in a drainback application. In a drainback system, a booster pump is typically used to provide the necessary lift to meet the head requirements on startup.



When configured for booster pump and delta T operation is required, the control adjusts the collector pump to full speed and turns on the booster pump for 3 minutes. After the 3 minute period elapses, the control turns off the booster pump and adjusts the collector pump to maintain the target temperature difference.

## Holiday Feature

The control includes a holiday feature that allows for the primary storage tank to expel heat out the collector in the event the storage tank is not being utilized such as vacation. In the event the storage tank is not being used it will be less capable of storing excess heat from the collector resulting in potential frequent cycles when the collector temperature increases. To reduce the potential for this type of operation to occur, the control operates to expel the heat from the storage tank to the collector resulting in a temperature drop from the storage tank. This will then allow for longer periods of operation when the collector temperature increases.

The holiday feature is activated when the holiday terminal is connected to the sensor common terminal. Once activated, the control adjusts the collector pump to full speed, and if applicable, turns on the auxiliary relay when the storage tank temperature is greater than storage tank maximum temperature and the storage tank temperature is 10°F warmer than the collector temperature. The output(s) then remain on until the storage tank temperature drops to 130°F. The holiday feature is only available when the 00-VT is configured for a single storage tank.

## Limit Input

The control includes a limit input feature that allows for certain operation to be terminated. The limit input operation is also dependent on whether the control is configured for one or two storage tanks.

If the 00-VT is configured for a single storage tank and collector sink operation, and a limit input is received, all outputs are turned off. However, the collector pump can still operate based on the requirements of the collector and the storage tank. This configuration would be typical of a pool being used as the auxiliary heat sink. In this case, a strap-on high limit pool aquastat could be used to provide a limit input terminating operation.

If the 00-VT is configured for two storage tanks or an application other than collector sink, and a limit input is received, all outputs are turned off. This configuration would be typical when servicing is required of the solar system requiring the control to be disabled.

## Intermittent Freeze Protection (DIP switch 4)

The 00-VT includes a freeze protection feature that intermittently operates the collector pump to prevent the potential of the fluid in the collector distribution system from freezing. The 00-VT turns on the collector pump when the collector temperature falls below 35°F. The collector pump then remains on until the collector pump rises above 40°F. This feature is selected by setting DIP switch 4 to the On position. It is recommended that this feature should only be used in a climate where the outdoor temperature does not remain below freezing for prolonged periods of time.



Note: Intermittent freeze protection does not apply when the 00-VT is configured for Drainback.

## Exercising

During long periods of no operation, the 00-VT is designed to exercise for 10 seconds every 3 days of no operation in order to prevent precipitate build-up in the pump. The % OUT LED turns on during the exercising function.

**WARNING:** Wiring connections must be made in accordance with all applicable electrical codes.

**CAUTION:** To prevent electrical shock, disconnect electric power to system at main fuse or circuit breaker box until installation is complete. When a service switch is installed, more than one disconnect switch may be required to deenergize this device for servicing.

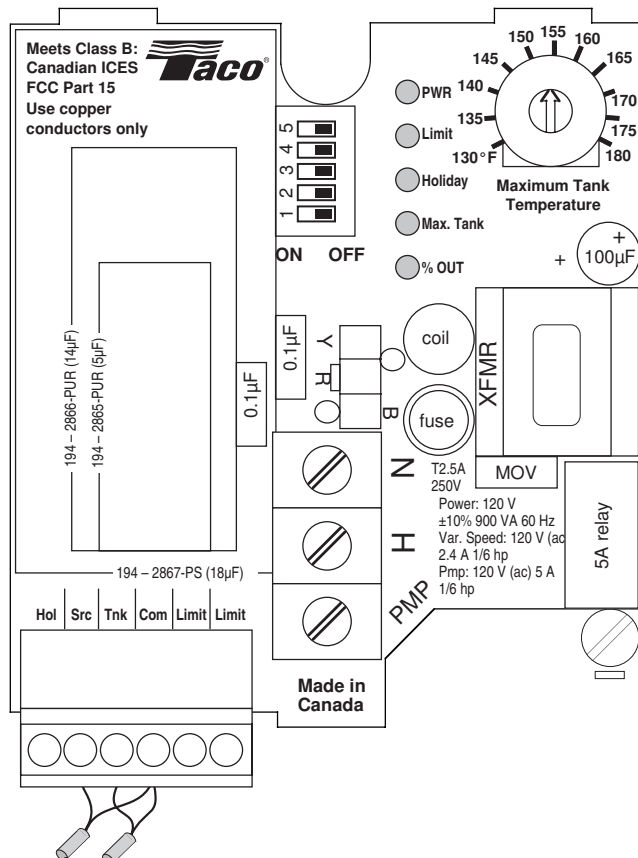

## Powering the control

Insert the line voltage wires through the knockout of the enclosure and connect the live wire to the H terminal and the neutral wire to the N terminal on the PC Board. Ensure that no power is present during this process.

## Limit Input

The limit input signal may be provided by shorting the Limit Com and Limit Dem terminals. 24 V (ac) applied across the terminals will also provide a limit input signal.

This signal may come from a switching device including a dry contact switch or high limit device.

## Sensors

Do not apply power to these terminals as this will damage the PC Board. The wiring terminals for the sensors may be removed for ease of installation.

Do not run the wires parallel to telephone or power cables. If the sensor wires are located in an area with strong sources of electromagnetic interference (EMI), shielded cable or twisted pair should be used or the wires can be run in a grounded metal conduit. If using shielded cable, the shield wire should be connected to the Com terminal on the PC Board and not to earth ground.

The sensors can be strapped directly to the pipe using a cable tie. Insulation should be placed around the sensor to reduce the effect of air currents on the sensor measurement. The sensors should be placed downstream of a pump or after an elbow or similar fitting. This is especially important if large diameter pipes are used because the thermal stratification within the pipe can result in erroneous sensor readings. Proper sensor location requires that the fluid is thoroughly mixed within the pipe before it reaches the sensor.

### **Collector Sensor (Src)**

Connect the two wires from the collector sensor (Src) directly into the Com and Src terminals on the PC Board.

### **Storage Sensor 1 (Tnk)**

Connect the two wires from the primary storage tank sensor (Tnk) directly into the Com and Tnk terminals on the PC Board.

### **Storage Sensor 2 (Hol)**

Connect the two wires from the second storage tank sensor (Hol) directly into the Com and Hol terminals on the PCB. The second storage tank sensor is only operational when the control is configured for 2 storage tanks.

### **Holiday Feature (Hol)**

To enable the holiday feature, short directly into the Com and Hol terminals on the PC Board. The Holiday feature is only available when the control is configured for 1 storage tank.

**WARNING:** Do not use in swimming pool or spa areas; pump has not been investigated for this application.

**WARNING** In the event the retaining screws have been pulled out of the housing, DO NOT replace them. Use of any other screw may short out the stator windings, creating a risk of electrical shock.

**CAUTION:** When installing electrical connections, do not apply mechanical loads to the capacitor box; otherwise, retaining screws may be pulled out of the housing, making circulator unusable.

## **Troubleshooting**

As in any troubleshooting procedure, it is important to isolate a problem as much as possible before proceeding. The error messages greatly simplify troubleshooting of the 00-VT. When the 00-VT flashes an error message, identify the fault and follow standard testing procedures to confirm the problem. If you suspect a wiring fault, return to the wiring section on this brochure and carefully check all external wiring and wiring connections.

For your safety and protection of permanent damage to the microprocessor, the 00-VT includes a 2.5 A 250 V (ac) field replaceable fuse.

## **Testing The Sensors**

A good quality test meter capable of measuring up to 5,000 k $\Omega$  (1 k $\Omega$  = 1000  $\Omega$ ) is required to measure the sensor resistance. In addition to this, the actual temperature must be measured with a good quality digital thermometer.

First measure the temperature using the thermometer and then measure the resistance of the sensor at the 00-VT. The wires from the sensor must not be connected to the PC Board while this test is performed. The wiring terminals are easily removed by pulling them from the PC Board. Using the chart below, estimate the temperature measured by the sensor. The sensor and thermometer readings should be close. If the test meter reads a very high resistance, there may be a broken wire, a poor wiring connection or a defective sensor. If the resistance is very low, the wiring may be shorted, there may be moisture in the sensor or the sensor may be defective.

To test for a defective sensor, measure the resistance directly at the sensor location.

Temperature		Resistance	Temperature		Resistance	Temperature		Resistance	Temperature		Resistance
°F	°C	$\Omega$	°F	°C	$\Omega$	°F	°C	$\Omega$	°F	°C	$\Omega$
-30	-34	234,196	30	-1	34,558	90	32	7,334	150	66	2,045
-20	-29	165,180	40	4	26,099	100	38	5,828	160	71	1,689
-10	-23	118,018	50	10	19,900	110	43	4,665	170	77	1,403
0	-18	85,362	60	16	15,311	120	49	3,760	180	82	1,172
10	-12	62,465	70	21	11,883	130	54	3,050	190	88	983
20	-7	46,218	80	27	9,299	140	60	2,490	200	93	829

## LED Status

LED	LED Status	00-VT Status
PWR	Solid	Power On
LIMIT	Solid	Limit Input present
HOLIDAY	Solid	Holiday feature enabled (holiday terminal connected to sensor common terminal)
MAX TANK	Solid	Maximum Tank temperature condition
% OUT	Flash (Solid)	Current variable speed output (100% speed)
MAX TANK	Flash	Tank sensor error. Control will not operate when error present.
HOLIDAY	Flash	Source (collector) sensor error. If open circuit error and freeze protection enabled then the control will operate at full speed. If open circuit error and the freeze protection feature is not enabled, or closed circuit error then the control will not operate.
LIMIT	Flash	Illegal DIP combination. If configured for Booster Pump and Drainback feature is not active then the control will not operate.
PWR	Flash	Illegal DIP combination. If Freeze Protection feature is active and Drainback feature is active then the control will not operate.
PWR, Holiday	Flash	Holiday (tank 2) sensor error. If configured for two storage tanks then control will not operate second storage tank.
Limit, Holiday	Flash	Manual override active. If both source sensor and tank sensor connected then removed, then the control will operate based on manual override feature.
PWR, Limit	Flash	Illegal DIP combination. If configured for two storage tanks and either heat exchanger application, tank supplement application or booster pump application then the control will not operate.

## APPLICATION

1. Maximum operating pressure: 125 psi (862 kPa) on all "00" Series Circulators, 200 psi (1379 kPa) on all Load Match® Circulators.
2. Maximum water temperature not to exceed nameplate rating.
3. Cast iron circulators are to be used for closed loop systems. Bronze circulators are to be used for open loop, fresh water, or potable water systems.
4. Taco Cartridge circulator pumps are for indoor use only – employer uniquement a l'intérieur.

## INSTALLATION

1. Mounting position – Circulator must be mounted with the motor in a horizontal position. It may be mounted vertically with the motor up, provided that the system pressure is at least 20 psi (138 kPa).
2. Rotating body – Body has an arrow on the front that indicates direction of flow. To rotate body, remove the four body bolts, rotate body and replace bolts. Make sure that the junction box is NOT located underneath the circulator. (The junction box must NOT be located in the 6 o'clock position, as viewed from the motor end.)
3. Electrical connections – Observe all applicable codes when connecting to power supply. The motor is impedance protected, and does not require overload protection. The pump cannot run backwards.
4. Fill system with tap water – The system must be filled before operating the circulator. The bearings are water lubricated and should not be allowed to operate dry. Filling the system will result in immediate lubrication of the bearings. It is always good practice to flush a new system of foreign matter before starting the circulator.
5. Circulator operation – Operate the circulator for 5 minutes immediately after filling system to purge remaining air from the bearing chamber. This is especially important when installing the circulator during the off-season.

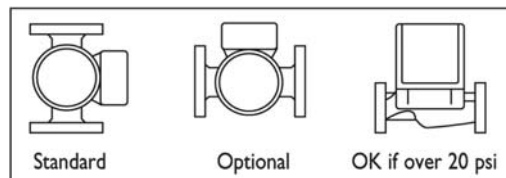

## Replacing Cartridge Assembly

1. Disconnect the electrical supply.
2. Reduce system pressure to 0 psi and allow system to return to room temperature. Isolate the circulator by closing the service valves or draining the system.
3. Remove the body bolts and swing motor assembly away from the body.
4. Pull cartridge out of the motor housing.
5. Install replacement cartridge, making sure that the cover plate is between the cartridge flange and motor.
6. Make sure the replacement cartridge corresponds to the full circulator product number. A complete parts list is available from your local plumbing supply wholesaler.
7. Reassemble the circulator using the new gasket and bolts supplied.
8. Follow the "Installation" procedure to start up the circulator.

## Replacing Integral Flow Check (IFC) Assembly (if applicable)

1. Disconnect the electrical supply.
2. Reduce system pressure to 0 psi and allow system to return to room temperature. Isolate the circulator by closing the service valves or draining the system.

3. Remove the body bolts and swing motor assembly away from the body.
4. Remove IFC, using needle nose pliers.
5. Install replacement IFC by pressing valve into casing until it is firmly seated.
6. Reassemble the circulator using the new gasket and bolts supplied.
7. Follow the "Installation" procedure to start up the circulator.

### Replacing Circuit Board

1. Disconnect the electrical supply and all field wiring to the circuit board.
2. Unplug the 3-pin plastic connector that connects the motor to the circuit board.
3. Bend the lip of the capacitor base to ease the removal of the circuit board. Pull the circuit board up and out.
4. Reverse directions to install the new circuit board.

**CAUTION:** 1. The addition of petroleum based fluids or certain chemical additives to systems utilizing TACO equipment voids the warranty.  
 2. Use supply wires suitable for 90°C

**ATTENTION:** Employer des fils d'alimentation adéquats pour 90°C.

**WARNING:** To avoid electrical shock, disconnect the power supply to the circulator and the main electrical unit.

## LIMITED WARRANTY STATEMENT

Taco, Inc. will repair or replace without charge (at the company's option) any product or part which is proven defective under normal use within one (1) year from the date of start-up or one (1) year and six (6) months from date of shipment (whichever occurs first).

Taco, Inc. will repair or replace without charge (at the company's option) any Taco 00 Series circulator cartridge that is proven defective under normal use within three (3) years from the date of start-up or three (3) years and six (6) months from date of shipment (whichever occurs first).

In order to obtain service under this warranty, it is the responsibility of the purchaser to promptly notify the local Taco stocking distributor or Taco in writing and promptly deliver the subject product or part, delivery prepaid, to the stocking distributor. For assistance on warranty returns, the purchaser may either contact the local Taco stocking distributor or Taco. If the subject product or part contains no defect as covered in this warranty, the purchaser will be billed for parts and labor charges in effect at time of factory examination and repair.

Any Taco product or part not installed or operated in conformity with Taco instructions or which has been subject to misuse, misapplication, the addition of petroleum-based fluids or certain chemical additives to the systems, or other abuse, will not be covered by this warranty.

If in doubt as to whether a particular substance is suitable for use with a Taco product or part, or for any application restrictions, consult the applicable Taco instruction sheets or contact Taco at [401-942-8000].

Taco reserves the right to provide replacement products and parts which are substantially similar in design and functionally equivalent to the defective product or part. Taco reserves the right to make changes in details of design, construction, or arrangement of materials of its products without notification.

TACO OFFERS THIS WARRANTY IN LIEU OF ALL OTHER EXPRESS WARRANTIES. ANY WARRANTY IMPLIED BY LAW INCLUDING WARRANTIES OF MERCHANTABILITY OR FITNESS IS IN EFFECT ONLY FOR THE DURATION OF THE EXPRESS WARRANTY SET FORTH IN THE FIRST PARAGRAPH ABOVE.

THE ABOVE WARRANTIES ARE IN LIEU OF ALL OTHER WARRANTIES, EXPRESS OR STATUTORY, OR ANY OTHER WARRANTY OBLIGATION ON THE PART OF TACO.

TACO WILL NOT BE LIABLE FOR ANY SPECIAL, INCIDENTAL, INDIRECT OR CONSEQUENTIAL DAMAGES RESULTING FROM THE USE OF ITS PRODUCTS OR ANY INCIDENTAL COSTS OF REMOVING OR REPLACING DEFECTIVE PRODUCTS.

This warranty gives the purchaser specific rights, and the purchaser may have other rights which vary from state to state. Some states do not allow limitations on how long an implied warranty lasts or on the exclusion of incidental or consequential damages, so these limitations or exclusions may not apply to you.

### Do It Once. Do It Right.™

TACO, INC., 1160 Cranston Street, Cranston, RI 02920  
 TACO (Canada), Ltd., 6180 Ordan Drive, Mississauga, Ontario L5T 2B3  
 Visit our web site at: <http://www.taco-hvac.com>

Telephone: (401) 942-8000  
 Telephone: (905) 564-9436

Fax: (401) 942-2360  
 Fax: (905) 564-9436

Copyright 2007 TACO, INC.  
 Portions Copyright 2007  
 tekmar Control Systems Ltd.  
 tekmar Control Systems Inc.  
 Printed in USA