



Buildings for the 21st Century

Buildings that are more energy-efficient, comfortable, and affordable...that's the goal of DOE's Office of Building Technology, State and Community Programs (BTS). To accelerate the development and wide application of energy efficiency measures, BTS:

- Conducts R&D on technologies and concepts for energy efficiency, working closely with the building industry and with manufacturers of materials, equipment, and appliances
- Promotes energy/money saving opportunities to both builders and buyers of homes and commercial buildings
- Works with State and local regulatory groups to improve building codes, appliance standards, and guidelines for efficient energy use
- Provides support and grants to States and communities for deployment of energy-efficient technologies and practices



AIR SEALING

Seal air leaks and save energy!

WHAT IS AIR LEAKAGE?

Ventilation is fresh air that enters a house in a controlled manner to exhaust excess moisture and reduce odors and stuffiness. Air leakage, or *infiltration*, is outside air that enters a house uncontrollably through cracks and openings. It is unwise to rely on air leakage for ventilation. During cold or windy weather, too much air may enter the house and, during warm or calm weather, too little. Also, a leaky house that allows moldy, dusty crawlspace or attic air to enter is not healthy.

The recommended strategy in both new and old homes is to reduce air leakage as much as possible and to provide controlled ventilation as needed. For simple house designs, effective spot ventilation, such as kitchen and bath fans that exhaust to the outside, may be adequate. For more complex houses or ones in colder climates, whole house ventilation systems may be appropriate. Such systems may incorporate heat recovery, moisture control, or air filtering.

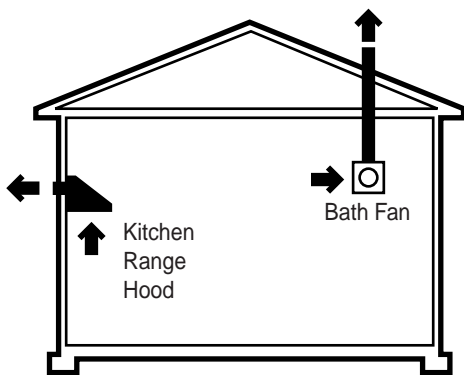

Kitchen and bath vents provide spot ventilation

WHAT ARE THE BENEFITS OF AIR SEALING?

Air infiltration can account for 30 percent or more of a home's heating and cooling costs and contribute to problems with moisture,

noise, dust, and the entry of pollutants, insects, and rodents. Reducing infiltration can significantly cut annual heating and cooling costs, improve building durability, and create a healthier indoor environment. The size of heating and cooling equipment can also be decreased, which saves additional dollars. Reducing air leakage in new homes, as required by the 1995 Model Energy Code (see page 4), typically costs less than \$200 for the average home and does not require specialized labor.

Annual Energy Costs for 1300 sq. ft. house			
	Infiltration rate		Savings
Atlanta	High*	Low**	
Heating	\$311	\$244	\$67
Cooling	\$196	\$178	\$18

* Estimated 12 air changes per hour at 50 Pascal pressure difference

** Estimated 6 air changes per hour at 50 Pascal pressure difference

WHAT IS AN AIR BARRIER?

The ceilings, walls, and floor/foundation that separate the inside conditioned space from the outside or unconditioned space form the air barrier and the insulation barrier for a house. These two barriers differ by the materials used.

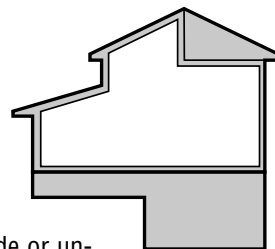

For most homes, the sheet goods that form the ceilings, walls, and floor (such as drywall, sheathing, and decking) are effective at stopping air leakage. It is critical to seal all holes and seams between these sheet goods with durable caulks, gaskets, and foam sealants to create a *continuous* air barrier. The insulation barrier is usually made up of standard insulating materials, such as batt or loose fill products, that do not seal against air leakage.

WHAT ARE THE PRIORITIES FOR AIR SEALING?

Although windows, doors, and outside walls contribute to air leakage, the biggest holes are usually hidden from view and connect the house to the attic, crawlspace, or basement. The key is to identify these areas during the design process, assign responsibility for sealing holes, and check to ensure that the air sealing was done effectively. Usually, seal all the big holes first, then the large cracks and penetrations, and finally the smaller cracks and seams.

WHERE ARE THESE LEAKAGE SITES?

Dropped ceilings and kitchen soffits, ductwork and plumbing chases, attic accesses and pull-down stairs, recessed light fixtures, holes in mechanical room closets, and wiring penetrations through the top plates of walls represent major connections between the attic and conditioned space. Many times unseen holes or pathways, called bypasses, occur at key junctures in the framing (such as at attic-to-kneewall transitions) and permit large quantities of air to leak in and out of the home.

Major leakage sites in the floor can be found around the tub drain and the numerous plumbing, HVAC, and wiring penetrations through the floor decking and bottom plates of walls. In walls, the band joist (for two-story homes), window and door rough openings, and penetrations through the drywall and exterior sheathing are primary leakage sites.

✓ AIR SEALING MATERIALS

Use a combination of these different air sealing materials.

- **Caulk:** Seals gaps of less than ½". Select grade (interior, exterior, high temperature) based on application.

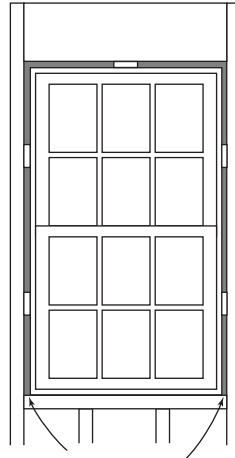

Use backer rod to fill gaps between window and rough opening before caulking or use non-expanding foam.

- **Spray foam:** Fills large cracks and small holes. It can be messy; consider new latex-based foams. DO NOT USE near flammable applications (e.g., flue vents). DO NOT USE expanding types on windows and doors.
- **Backer rod:** Closed-cell foam or rope caulk. Press into crack or gap with screwdriver or putty knife. Often used with caulk around window and door rough openings.
- **Gaskets:** Apply under the bottom plate before an exterior wall is raised or use to seal drywall to framing instead of caulk or adhesive.
- **Housewrap:** Installed over exterior sheathing. Must be sealed with housewrap tape or caulk to form an airtight seal. Resists water but is *not* a vapor barrier.
- **Sheet goods** (plywood, drywall, rigid foam insulation): These materials form the air barrier. Air leaks only at unsealed seams or penetrations.
- **Sheet metal:** Used with high-temperature caulk for sealing high-temperature components, such as flues and chimneys, to framing.
- **Polyethylene plastic:** This inexpensive material for air sealing also stops vapor diffusion. All edges and penetrations must be completely sealed for an effective air barrier. Poly is fragile, and proper placement is climate specific.
- **Weatherstripping:** Used to seal moveable components, such as doors, windows, and attic accesses.
- **Mastic:** Seals air handlers and all duct connections and joints.
- **UL181 or foil-faced tape:** Temporarily seals the air handler.

DIAGNOSTIC TOOLS

Testing the airtightness of a home using a special fan called a blower door can help to ensure that air sealing work is effective. Often, energy efficiency incentive programs, such as the DOE/EPA ENERGY STAR Program, require a blower door test (usually performed in less than an hour) to confirm the tightness of the house.

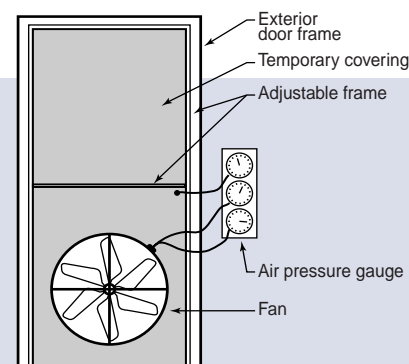

DON'T RELY ON THE INSULATION:

The most common insulation, fiberglass, does *not* stop air leakage. In older homes, dirty fiberglass is a telltale sign of air movement (it simply collects dirt like a filter). Certain types of insulation, such as dense-packed cellulose and certain foams, can be effective at reducing air flow as well as heat flow.

AIR SEALING

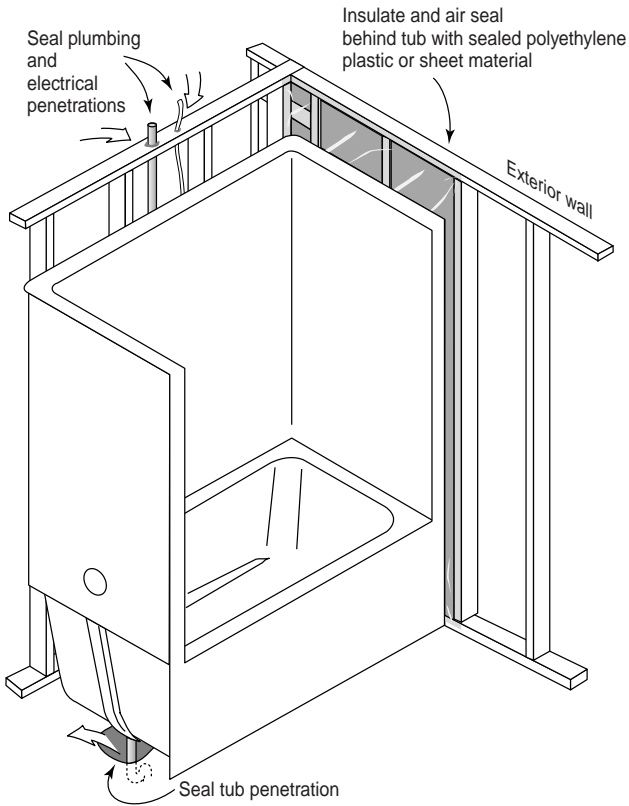

Seal and insulate exterior wall before installing bath tubs.

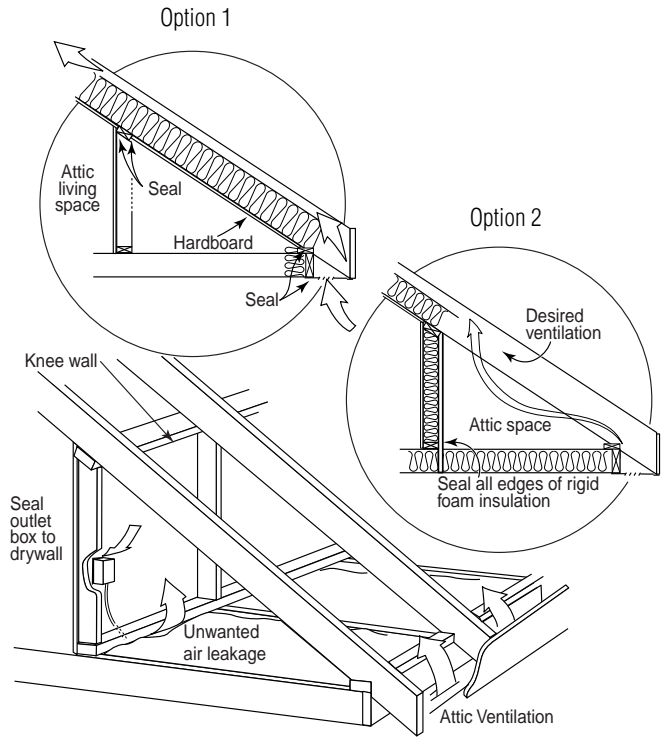

Seal kneewall to create a continuous air barrier.

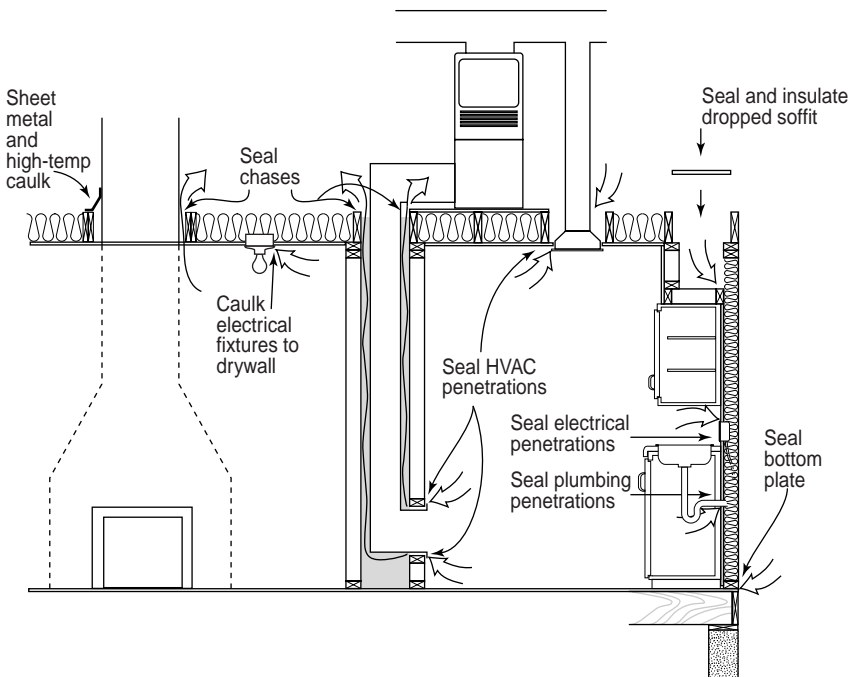

Seal dropped soffit ceilings, plumbing and electrical penetrations, and utility chases.

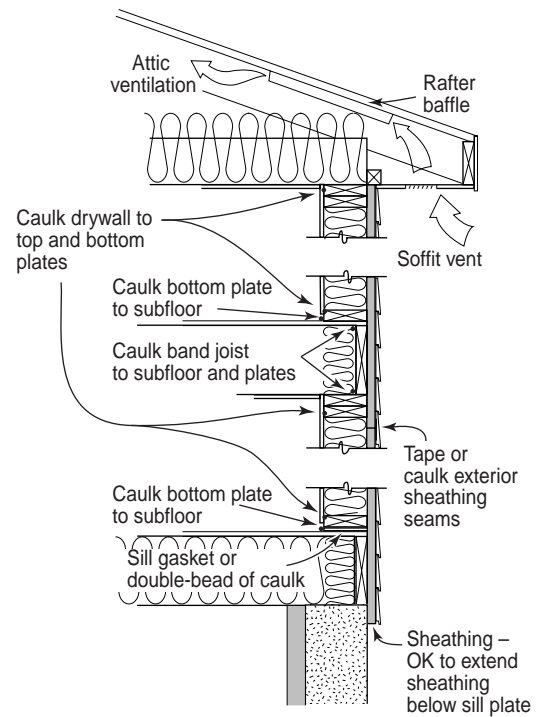

Seal exterior sheathing joints, and top and bottom plates.

AIR SEALING

For more information, contact:

Energy Efficiency and Renewable Energy Clearinghouse (EREC)
1-800-DOE-3732
www.eren.doe.gov

Or visit the BTS Web site at www.eren.doe.gov/buildings

Or refer to the Builder's Guide Energy Efficient Building Association, Inc.
651-268-7585
www.eeba.org

Written and prepared for the U.S. Department of Energy by:

Southface Energy Institute
404-872-3549
www.southface.org

Oak Ridge National Laboratory
Buildings Technology Center
423-574-5178
www.ornl.gov/ornl/btc

The Model Energy Code can be obtained from the International Code Council by calling 703-931-4533

MECcheck, a companion compliance software package, can be ordered from DOE by calling 1-800-270-CODE or downloaded directly from the Web at www.energycodes.org/resid/resid.htm.

NOTICE: Neither the United States government nor any agency thereof, nor any of their employees, makes any warranty, express or implied, or assumes any legal liability or responsibility for the accuracy, completeness, or usefulness of any information, apparatus, product, or process disclosed. The views and opinions of authors expressed herein do not necessarily state or reflect those of the United States government or any agency thereof.

AIR SEALING CHECKLIST

✓ BEFORE DRYWALL

- Seal bottom plate of exterior walls with caulk or gasket; seal inside edge with caulk after walls are up.
- Seal band joist with caulk, spray foam, or gasketing between top plate and band joist, and between band joist and subfloor.
- For bath tubs on outside walls, insulate the exterior wall and air seal behind tub with sheet goods or plastic before tub is installed. After the drain is installed, seal the tub drain penetration with sheet goods and caulk or spray foam.
- For dropped ceilings or soffits, duct and flue chases, and open partition walls, use sheet goods and sealant to stop air leakage from attic into soffit and then insulate. Alternately, install framing and drywall for the soffits *after* the taped ceiling drywall is installed.
- Caulk the backsides of window flanges to the sheathing during installation.
- Seal between door thresholds and subflooring with caulk.
- Seal window and exterior door rough openings with backer rod and caulk, or use non-expanding latex-based spray foams that will not pinch jambs or void window warranties.
- Seal all electrical wire, plumbing, and HVAC penetrations between any conditioned and unconditioned spaces with caulk or spray foam.
- Seal wiring and knockouts in electrical boxes with caulk. Also seal outdoor-mounted boxes to the exterior sheathing.

✓ DURING DRYWALL

- Seal drywall to top and bottom plates using gaskets, adhesive, or caulk.

✓ AFTER DRYWALL

- Seal electrical switch, outlet, and circuit breaker boxes to drywall with caulk or foam.
- Seal light fixture boxes, medicine cabinets, and bath and kitchen ventilation fans to drywall with caulk or foam.
- Seal all duct boots to floor or drywall with caulk, foam, or mastic.
- Seal any plumbing or electrical wire penetration through drywall with caulk or foam.
- Seal gaps at whole house fan with spray foam or housewrap tape (ensure louvers function properly).
- For attic hatches and kneewall access doors, weatherstrip and include a tight latch. Add rigid insulation.
- For attic pull-down stairs, make stairs airtight using latch bolts and weatherstripping. Add an insulated cover.
- Seal between a masonry chimney and the attic framing using sheet metal or other noncombustible sheet goods and high-temperature (450°F), fire-rated caulk.
- Seal around the metal flue of combustion equipment using a UL-approved metal collar and high-temperature (450°F), fire-rated caulk.
- Use only UL-approved airtight, IC-rated recessed light fixtures (that meet ASTM E283 requirements); seal between fixture and drywall with caulk.

✓ AIR SEAL EXTERIOR

- Repair any damaged sheathing pieces.
- Seal all exterior penetrations, such as porch light fixtures, phone, security, cable and electric service holes, with caulk or spray foam.
- If not using housewrap, seal all sheathing seams with housewrap tape or caulk.



Printed with a renewable-source ink on paper containing at least 50% wastepaper, including 20% postconsumer waste.
November 1999 DOE/GO10099-767