

Ref
Ser
TH1
N21b8

ISSN 0701-5216

no. 30

BLDG

IRC PUB

BUILDING PRACTICE NOTE

DESIGN AND CONSTRUCTION
OF LOW ENERGY HOUSES IN SASKATCHEWAN

by

LIBRARY
ANALYZED

H. W. Orr

Division of Building Research, National Research Council of Canada

Ottawa, April 1982

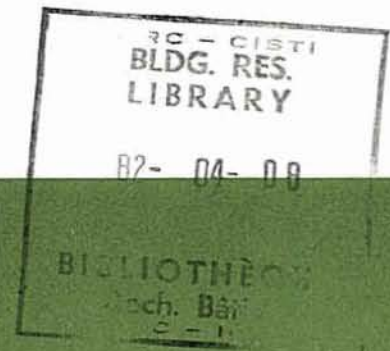

DESIGN AND CONSTRUCTION OF LOW ENERGY HOUSES IN SASKATCHEWAN

by

H.W. Orr

As a result of the need to reduce energy use there has been an interest on the part of government and some private individuals in constructing super-insulated houses, sometimes called low energy houses. In these houses, thermal resistances of the walls and ceiling are typically RSI 7 (R 40) and RSI 10 (R 57), respectively; special efforts are usually made to keep air infiltration to a minimum.

It should be noted that these are unusual buildings; only two or three hundred such houses have been built in Canada. Thus they represent a small fraction of one per cent of dwellings constructed in this country in the past two or three years. Observation of some of these houses indicates that, when compared with conventional houses, significant reductions in energy consumption have been achieved. Continued observation of their performance and documentation of details of construction constitute an important contribution to the development of housing in Canada.

This report provides some of the background of this development on the Prairies. It describes details of wall and foundation designs that have been used. It does not address the question however of whether these details are justifiable from an economic standpoint.

The dimensions of wall studs in houses are usually governed by structural needs. The amount of thermal insulation required by current building regulations can be fitted into the 89 mm (3½-in.) wall space provided by 2 x 4 studs. This space, filled with 24 kg/m³ mineral wool, provides about RSI 2.1 (R 12); taking other wall components into account produces RSI 2.5 (R 14.2).

In the past few years, several innovations in wall design have appeared which provide for greater thermal resistances. In some new houses, rigid insulation, usually 38 mm (1.5 in.) thick, is applied outside of 38 x 89 mm (2 x 4) wall studs. In some others, 38 x 140 mm (2 x 6) studs are used. When filled with mineral wool or equivalent insulation, these produce a thermal resistance of about RSI 3.7 (R 21).

The desire to incorporate still more insulation has led to the development of the double framing system in which two sets of wall

studs are used, one at the outside and the other at the inside of the wall. In this way, walls of almost any thickness can be built without adding significantly to the cost of wall framing material. Also, in this system, the studs do not extend through the wall and thermal bridging is therefore reduced.

Studies have demonstrated the importance of a complete air-vapour barrier in controlling wall condensation and heat loss due to air infiltration. Traditionally, air-vapour barriers are placed between the drywall and the studs. Faults in the air-vapour barrier membrane occur at joints at the top of the interior partitions, around floor joists in each floor system, at the top and bottom of exterior walls, around windows and doors, and around penetrations for electrical fixtures and wires, vent stacks for plumbing, and chimneys and attic hatches. These deficiencies can be attributed in part to poor application of the air-vapour barrier, damage by other trades, wood shrinkage and to the design which often makes good application extremely difficult to achieve.

These deficiencies in the air-vapour barrier in walls can be largely avoided in the double frame system. The air-vapour barrier is located at the outside of the structural framing members, thus providing a space for electrical wiring and outlets, and other mechanical installations to be installed without penetrating it. Further, its installation as an integral part of the wall avoids the application problems inherent in the traditional method, and allows detailed inspection of the air-vapour barrier before it is covered.

The double frame system requires construction procedures different from those used for conventional walls. A procedure that has been found in the field to be convenient is as follows:

1. The wall is built in the horizontal position on the house floor. The interior structural frame is constructed first. It is straightened and squared in preparation for the sheathing.
2. The 150 μm (6 mil) polyethylene is placed on the cold side of the inner frame and laps over the top and bottom plates and end studs (Figures 1, 2 and 3).
3. The sheathing is applied to hold it in place, care being taken to protect the air-vapour barrier when the sheathing is cut to size and to ensure its integrity at window and door openings.
4. The exterior frame is then constructed on top of the sheathed interior wall. Window and door openings are constructed to match exactly the openings in the interior frame. The inner frame provides the structural strength, therefore the outer one does not require structural headers or cripple studs for the windows and doors, or double plates, and can be made

of 38 x 38 mm (2 x 2) or 38 x 63 mm (2 x 3) material.

5. When the exterior frame has been completed it is squared. It is then raised onto temporary supports so that the space between inner and outer frames can be set. Plates of plywood, 7 mm (5/16 in.) are used to hold the walls at the correct spacing. They are nailed or stapled to the top and bottom plates to complete the framing of the wall. This holds the frames in their proper, relative positions, and provides final straightening.

6. When the wall is raised to the vertical position, properly located on the floor and nailed in place, it is necessary only to brace the wall at the ends. No further straightening is necessary before putting on roof trusses or floor joists for the next stage of construction. The continuity of the air-vapour barrier is provided by a bead of acoustical sealant, which is added when the polyethylene is applied to the ceiling or over the joist headers for intermediate floors.

The air-vapour barrier is located well away from the inner face of the wall and will be somewhat colder than in more common designs. It has been assumed that at least 2/3 of the thermal resistance should be placed on the cold side of the air-vapour barrier. If the interior stud space contains insulation of RSI 2.3 (R 13) the total resistance of the wall would have to approach RSI 7 (R 40) to achieve this.

In conventional house design, the space between the top plate and the roof is not large enough to allow much insulation to be placed on top of the plate. In low energy houses, high lift trusses are used. Insulation 250 to 300 mm (10 to 12 in.) thick can be placed directly over the plate and still permit air to flow from the soffit into the attic for attic ventilation. Plywood sheathing and/or cardboard soffit baffles, made for this purpose, prevent this insulation from falling into the soffit space. The "high lift" effect is obtained by using trusses 1200 mm (4 ft.) longer than normal or by using specially designed roof trusses.

Basements are used in some cases; in others a crawl space is employed. In both instances large amounts of insulation have been installed. Special designs may be needed for basement walls to accommodate the large amount of insulation and at the same time to meet the structural requirements imposed by horizontal soil pressures.

Three different double stud wall designs are shown in Figures 1 to 3. One or more houses have been built following each of these designs.

Energy consumption data have been obtained for the house represented in Figure 2. It has two storeys, no basement, and a total floor area of approximately 250 m². The estimated annual energy consumption for space heating based on the measured energy input to the house was 35 GJ.

The estimated space heating energy consumption for a conventional house of that size would be 210 GJ. Both values are based on 5600 °C heating degree-days - the number measured in the test year. A preliminary report on energy consumptions in other houses of similar type has been prepared.¹

Pressure tests have been carried out on a number of houses, including 21 low energy houses. Nine were of double stud construction with the vapour barrier placed in the wall as shown in Figures 1 to 3. In the twelve other houses, which had been constructed with careful attention to the vapour barrier, it was placed in the normal location -- behind the dry wall. The air leakage rates at a pressure of 50 Pa were compared. For the double stud walls the average leakage rate was 0.78 air change per hour (ach) with a standard deviation of 0.32 ach; for the other houses the average leakage rate was 1.80 ach and the standard deviation was 0.88 ach. For these cases it appears that the double stud design resulted in significantly lower air leakage rates and suggests that air tightness is more easily achieved with this design than with other types of construction.

Construction costs for a double stud wall will be significantly higher than those of conventional houses. Tests indicate that with proper construction practices the expected savings in energy for space heating are achieved. The economics cannot be properly assessed at this time since a simple comparison of construction costs and energy saved does not include the benefits to the country of savings in non-renewable resources or reduced cost to municipal and provincial governments of services required to supply energy to the houses.

Reference

- ¹ Dumont, R.S., Orr, H.W., Hedlin, C.P. and Makohon, J.T. Measured Energy Consumption of a Group of Low Energy Houses. Procs., Joint Solar Conference, University of British Columbia, Vancouver, B.C., 6 to 10 August 1980. The Solar Energy Society of Canada Inc. and the Pacific Northwest Solar Energy Association. p.294-298.

* SPACING OF STUDS
DEPENDS ON SIDING USED

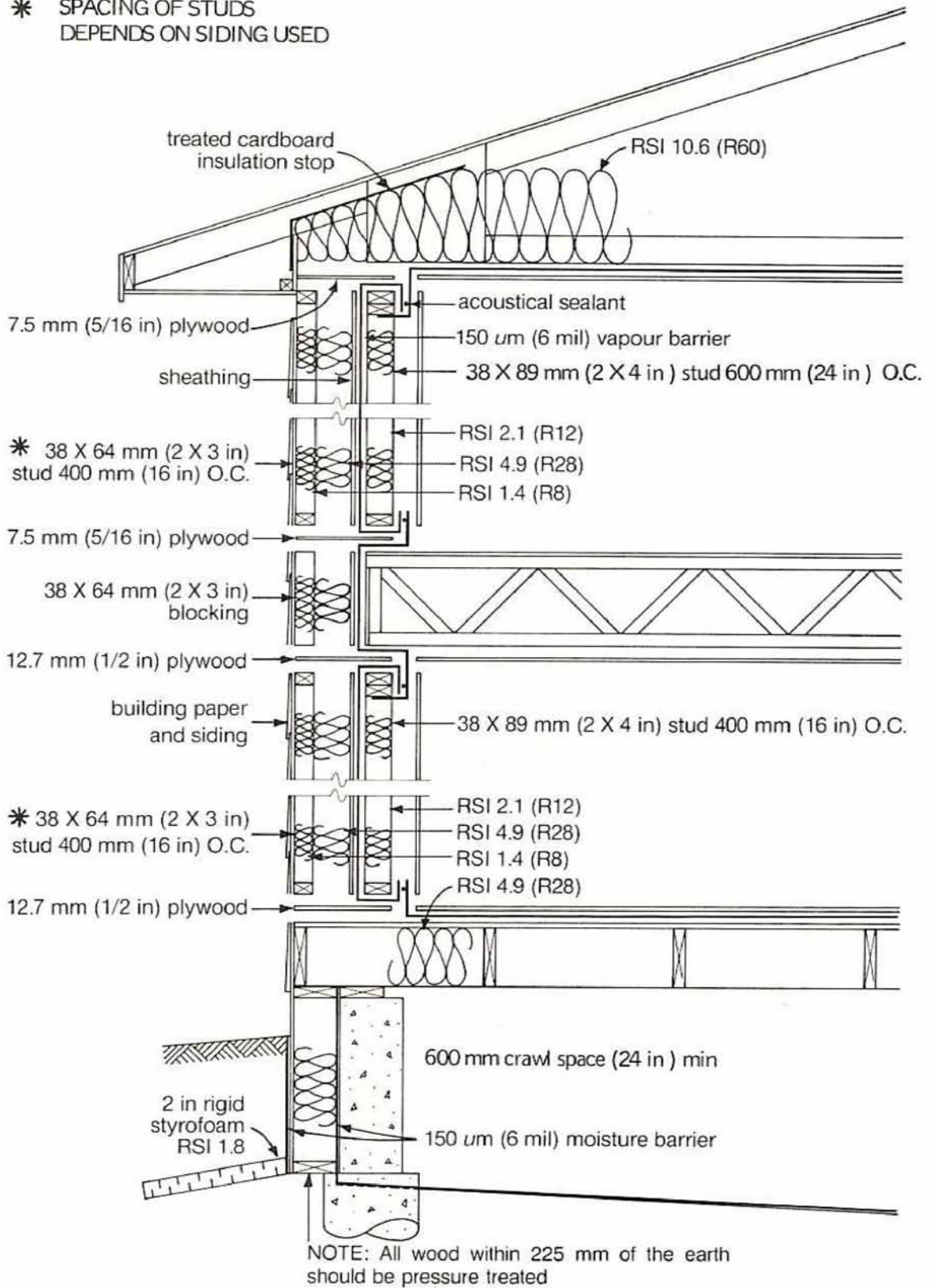

FIGURE 1 Wall section - grade beam and piling foundation

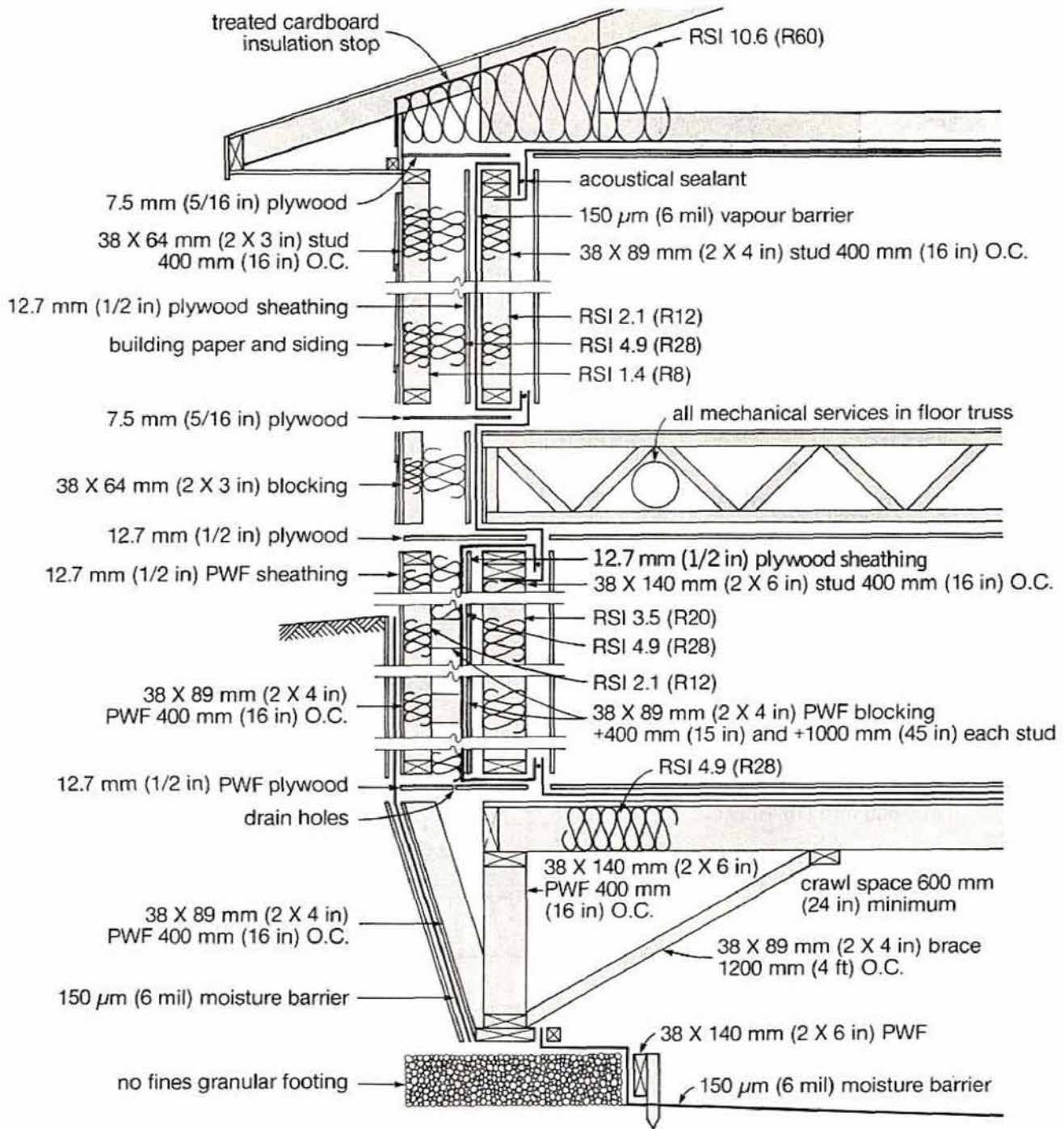

FIGURE 2 Wall section - pressure treated wood foundation

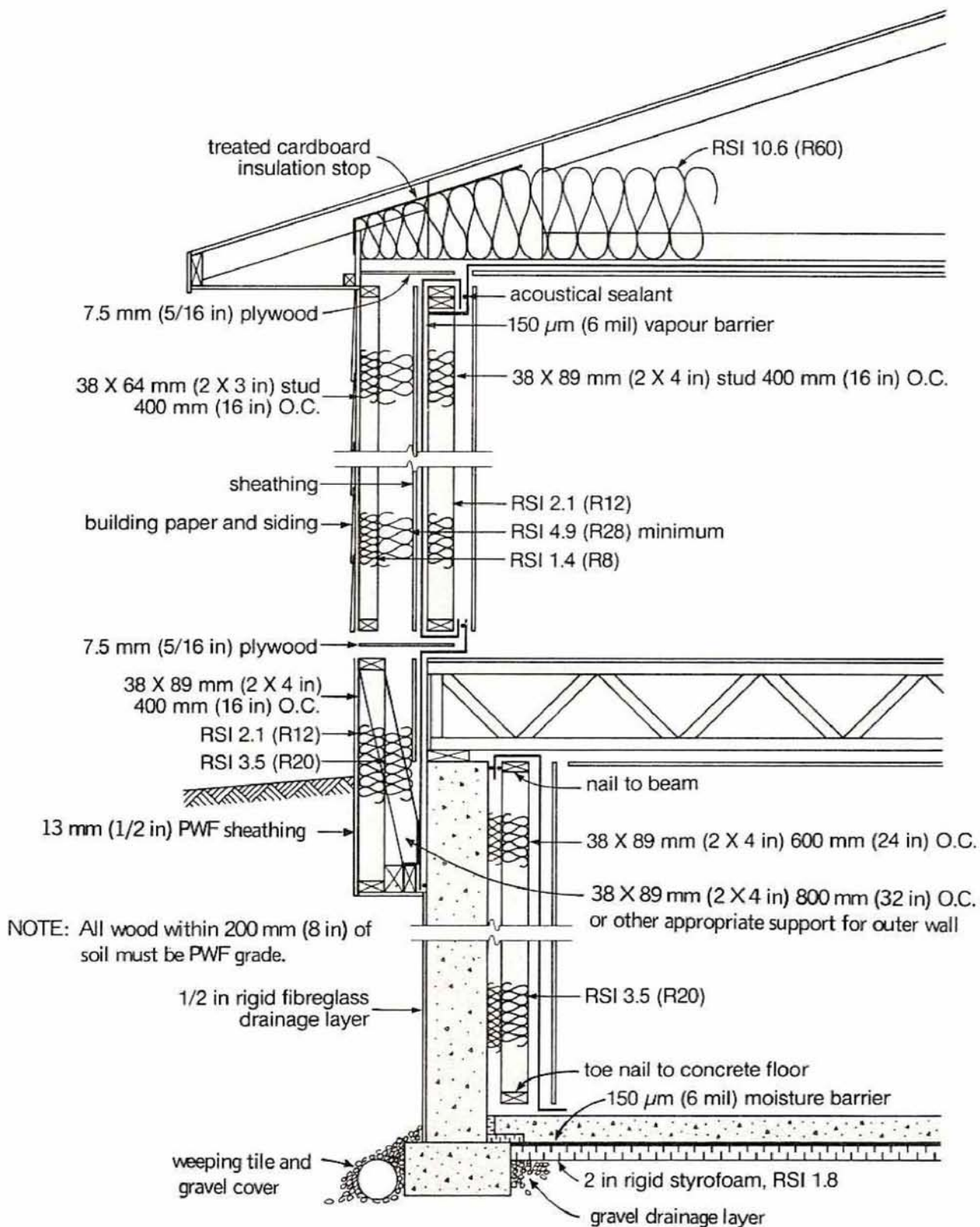

FIGURE 3 Wall section - concrete wall and footing foundation