

Assembling your 3phase turbine Kit

Turbine Kit Parts List

- | | |
|----|--------------------------------------|
| 1 | 1 Stator (slotted thingy) |
| 2 | 2 Blade mounts (triangular plastic) |
| 3 | 1 8 inch x ¼ inch threaded rod |
| 4 | 2 ¼ inch standard nuts |
| 5 | 1 ¼ inch nyloc nut |
| 6 | 2 ¼ inch washers |
| 7 | 3 Aluminum Blades |
| 8 | 6 Neodymium magnets 1" x .5" x 1/8" |
| 9 | 3 50 turn coils of magnet wire |
| 10 | 15 #4 x ¼ phillips head screws |
| 11 | 6 N4001 diodes |
| 12 | 1 3 ½ " steel disc |

Tools you will need to assemble this kit

Drill

3/32 drill bit

1/8 drill bit

¼ drill bit

#1 Phillips screwdriver

Pliers

7/16" wrench

Tape

Super glue

Mild grease or oil

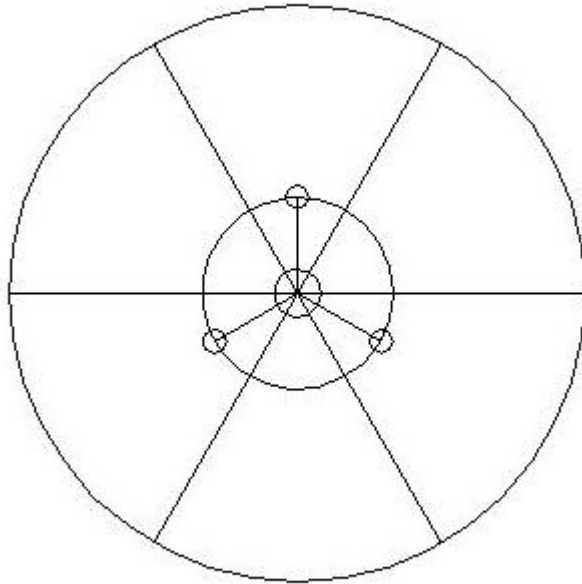

Start by finding the steel disc and cut out the template above. A flashlight is handy to line up the center hole. Lay the steel disc on the flashlight and lay the template over the disc. Line up the center hole with the light shining through the hole. This will center the template. Tape the template in place and use a center punch to mark the 3 holes. Use a marker to mark the lines on the disc where the magnets will be placed. Remove the template and drill the marked 3 hole locations using a 1/8 inch drill bit. When this is done take a ruler and connect all the lines on the disc. This will be the placement of the magnets. The two triangles have small divits in the sides and top. Use a 3/32" drill bit to drill into these divits.

Continue by locating the steel disc, triangles, 2 washers and threaded rod as well as the 2 standard nuts as shown below.



Take one of the nuts and screw it on the threaded rod about 2 inches down. Place one of the washers on the rod and one of the triangles with the washer groove toward the washer. Place the second triangle on the other one with the washer groove up as well as another washer. Install the steel disc with the lines showing and install a nut. Line up the 3 holes in the steel disc with the 3 holes in the triangle. Install the 3 screws to hold the disc in place. This assembly is to assure the disc is centered on the triangle. Below shows the assembly jig assembled.

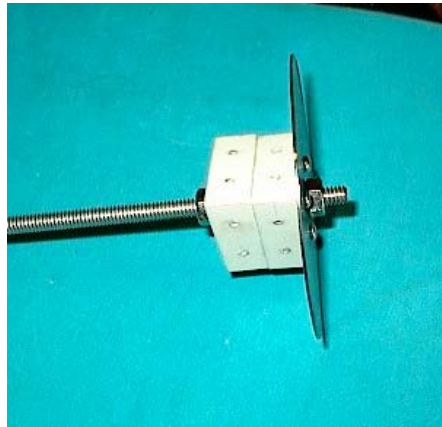

Remove the disc and triangles from the rod and find the 3 turbine blades. Install one turbine blade on the triangle attached to the disc. Attach the other triangle to the top of the blade. Make sure you have the washer groove upward and the triangle lines up with the blade. Below shows the first blade assembled and the turbine assembled.



Flip the unit over showing the steel disc and find the magnets. The magnets have to be placed on the disc with alternating poles. Such as North, South, North, South etc. It really doesn't matter which is north or south as long as they alternate. The simplest way

to do this is to place the first magnet down on the disc centering in on one of the lines. These can be superglued in place if necessary.



Take the next magnet and hold it a distance away from the magnet already on the disc, If it attracts then flip it over... it should repel. This is the way it should go down on the next line same as the first. Remember the magnet should repel the one before it. The rest of the magnets can be installed at this point. When you get to the fifth one it's a good idea to double check your work using the last one to test the poles. Circling the poles one should attract the next repel and so on. The last magnet will repel both the ones beside it.



This portion of the turbine is completed for now. Set this aside and find the 3 coils of wire and the stator (slotted plastic thingy). As shown below...



Untwist the coils and take one from the three. Notice there are two wires coming out from the coil. One wire is short and one is longer. When installing the coils the short wire should be on the right hand side. The short wire represents the “Start” of the coil and the long one is the “End” of the coil. Using some tape and a marker label the ends of the coil 1S and 1E. A fine point sharpie works nice for this. Below shows the coil with the ends labeled...

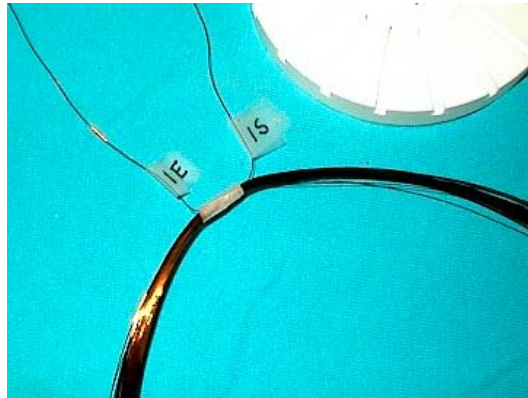

At this point you should get some tape ready to help hold the wires in the slots as we go along. Cut 6 pieces about 1 inch long and stick them to the table edge or somewhere easily accessible. Bend the wire to a 90 degree angle just left of the edge of where the two wires come out of the taped connection. You can place this in any slot to start with and place a piece of tape over the slot to hold the wire in place as shown below...

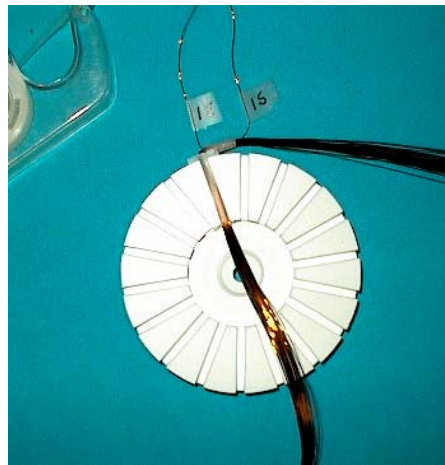

Bring the bottom of the wire, leaving a small loop while skipping two slots back up through the slot as shown below....

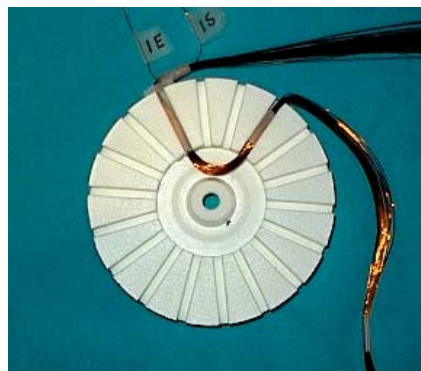

The top wire will come down through the same slot forming one of the six coils to be completed. A piece of tape covering the slot will hold the wires in place once again. The picture below shows the completed first coil...

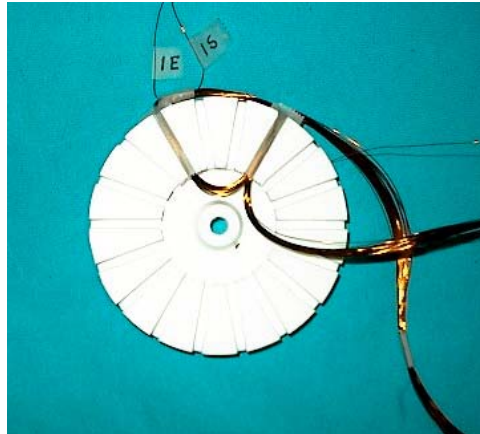

The next coil will be similar to the first, skipping 2 slots, the bottom wire goes up through the slot and the top coming down through the same slot. A piece of tape to hold the wires in the slot. Below shows the next coil in place...

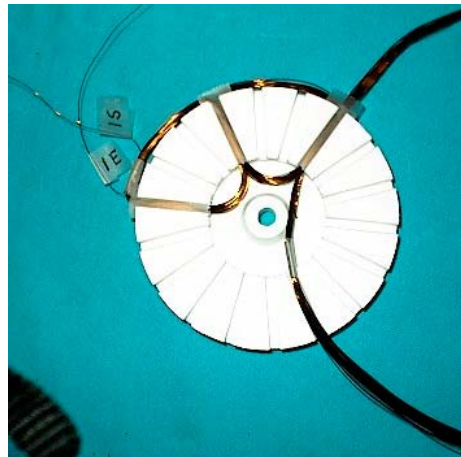

Continue on until all the coils are in place. The last coil will share the same slot as the starting coil. You'll have to pull the tape up, install the wire and replace the tape. When completed should look like the one below...



Now you have completed all the coils of one phase. You've just created a single phase alternator. The next two phases will go in the same as the first. The next phase will start in the slot directly to the right of the start of the first phase. Start by finding the long and short wire as with the first coil and label the start and end as you did with the first only this one will be labeled 2S and 2E for the second phase. Shown below is the beginning of the second phase...



Follow the same pattern as you did with the first phase and using tape to hold the wires in place. Below shows the second phase in place...



Proceed with the third phase the same as the first two filling the remaining slots. Shown below is the first coil start and the completed stator...



That completes the stator at this point. Assembling the stator to the turbine is a simple step. But, before we continue you should decide on the base. The base can be a board with feet which I will show in the following assembly or you can use a PVC pipe plug that will fit a pole to mount it on. Simply drill a hole in the plug and bolt the stator to the plug. Makes a nice pole mounted unit for experimenting. For simplicity I've chosen to make this one on a wooden base. A simple square of wood and 4 feet has been made for the instructional version. Below shows the base ...

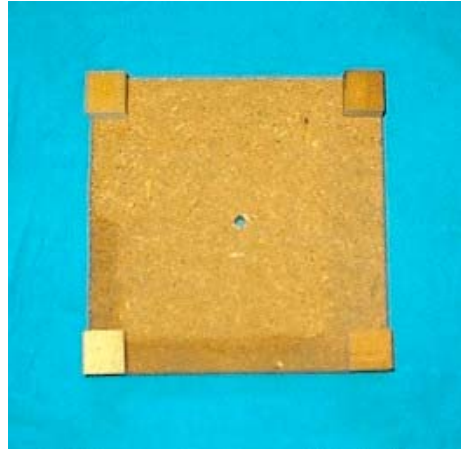

A $\frac{1}{4}$ inch hole has been drilled through the center for mounting the stator and 4 wood feet glued to the base. Mount the stator using the threaded rod and two nuts provided in the kit. Below shows the stator mounted to the base...



Slide the magnet end of the turbine unit over the rod, install a washer on top making sure it drops into the washer groove of the triangle and install the nyloc nut provided in the kit. When tightening this nut make sure its not tight against the washer but not loose enough to allow the washer to jump out of the slot. The turbine should rotate freely. Make sure the magnets are not hitting the stator or wires and rotates without much friction. If the lower hole is difficult to install on the rod you can run a ¼ inch drill through the hole to make sure its free of burrs. Also a little grease or oil can be applied at the top and bottom pivot points to further reduce any friction created at these points. Below shows the completed turbine on base...

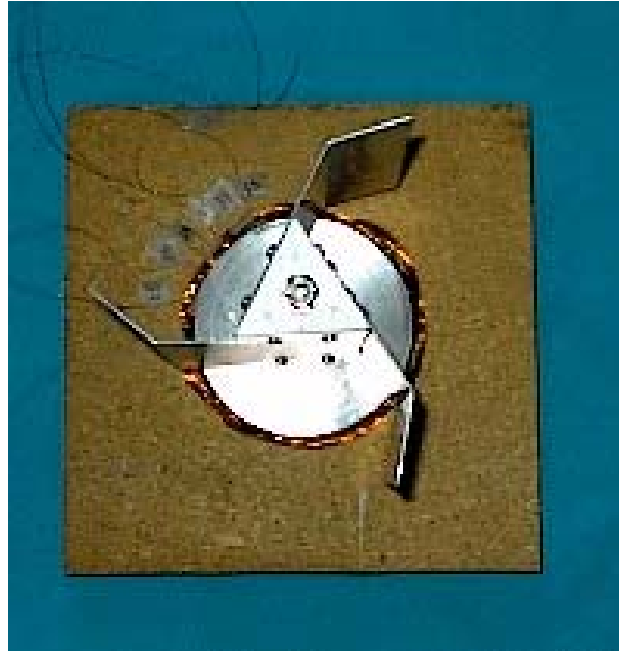

To make the stator a bit more permanent you can coat the wires with a clear enamel. This will help stiffen the looseness of the wires and hold them in place much better. Polyester resin works well also if you have some on hand .

From here we need to wire it up so it can actually do some useful work. There are basically two ways to wire a 3 phase alternator, star and delta. The “star” configuration gives you more volts but less amps and the “delta” gives you less volts but higher amps. I will show you how to wire it both ways but for the instructional model I will wire it in star.

The connections of the wires for star configuration are:

1S – 2E – 3S are output wires
1E – 2S – 3E are all connected together

The connections of the wires for delta configuration are:

1S to 3E

2E to 1E
3S to 2S
each of the three pairs are output leads.

Below is a diagram of star and delta configurations...

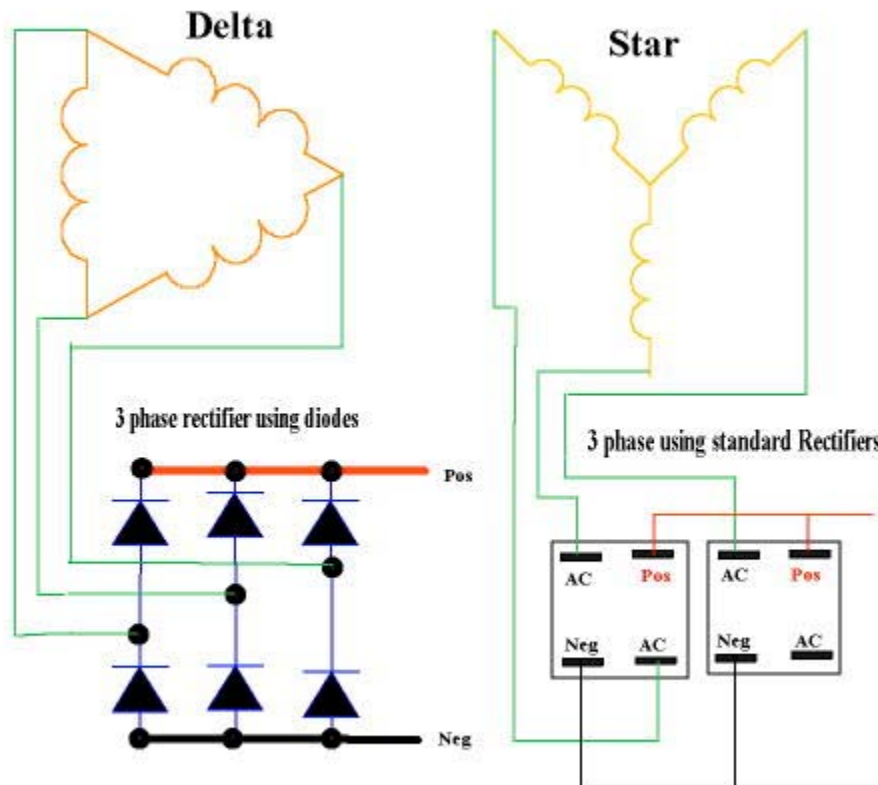

We will be using diodes to rectify the AC voltage coming from the alternator to DC voltage. Shown above in the delta configuration. You can use standard rectifiers shown above in the star configuration but with the power this unit makes the diodes are sufficient.

Since the output of the alternator is in the form of AC (alternating current) its not storable. To make it storable we convert it to DC (direct current). In order to do this we will use standard diodes to make a rectifier. Notice the band around the diode, it is on the end in which the direction the voltage/current will flow. You can connect the diodes together by soldering the ends or simply twisting them together. I have twisted the sets together for simplicity but soldering them makes a nicer looking end product. Below shows the pairs of diodes twisted together...

The picture isn't very clear but if you look closely each of the pairs are going in the same direction. That is to say the band shows the flow from left to right. The twisted portions shown here will be the AC inputs.

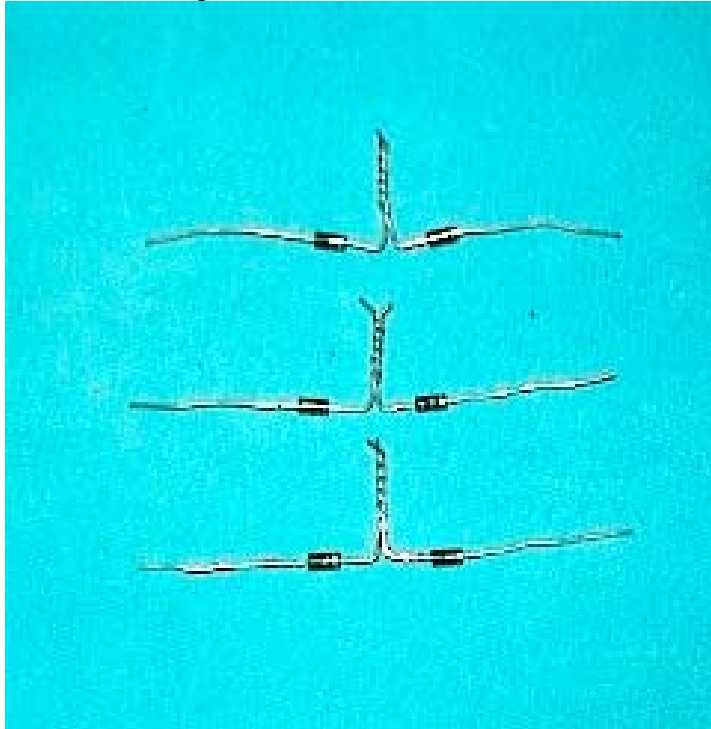

The next picture shows the ends of the 3 pairs twisted together forming the pos (+) and the neg (-) sides of the diodes. These are the ends that will connect to a battery for charging or become the outputs for powering an LED light or other. You can purchase a battery holder and NiCad batteries from Radio shack and wire it to the rectifier. Below shows the diode rectifier twisted together to form the rectifier (left) and input and output of the assembly (right)...

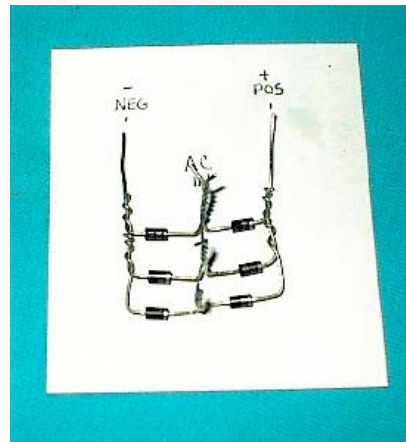
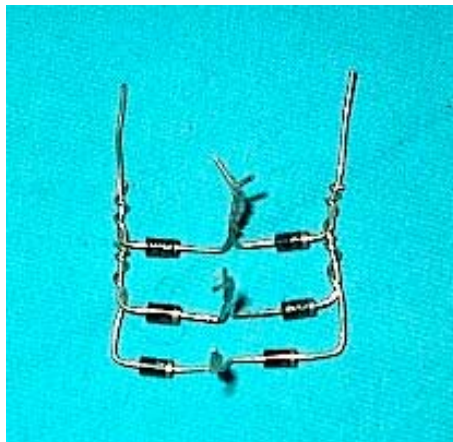

To complete your system you can install a Zenier diode of 3 volts and an led to make a simple shunt regulator. When the batteries reach 3 volts the light comes on telling you the batteries are charged and burns off the extra voltage. If the wind stops and the

batteries are not being charged anymore the light will burn off any excess in the batteries. When the voltage drops to just below 3 volts the light will go out leaving the batteries at a full charge. The simple shunt diagram is shown below...

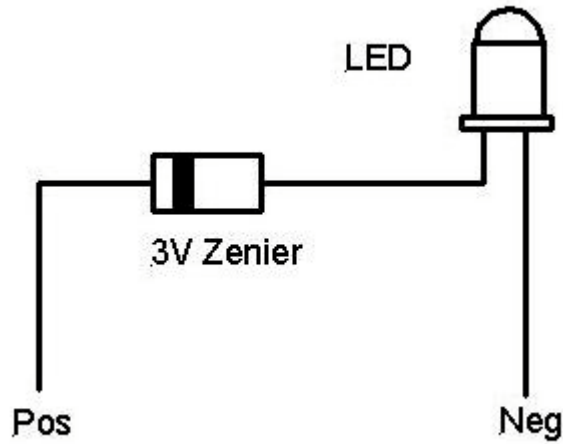

Below is the alternator wiring diagrams for both “star” and “delta” configurations ...

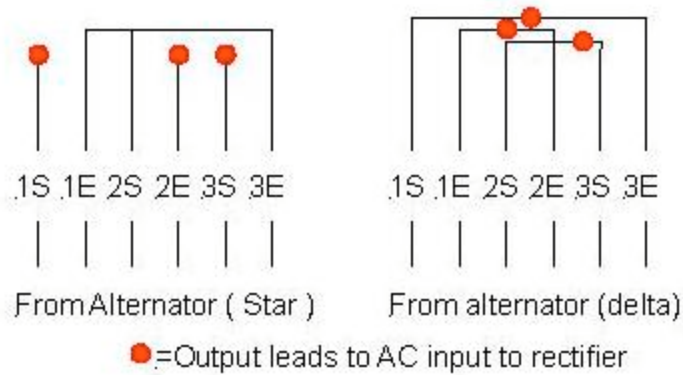

Now you have a completed RE (Renewable energy) system. Experiment and have some fun !!!